

Fine grinding mills

Kek® Universal Mills
for fine grinding
soft to medium hard
pharmaceutical,
chemical, and food
products



**Kek®
Universal
Mill**



Features

- Fine grinding 30 - 500µ
- Easily accessible and interchangeable grinding media
- Adjustable mill speed
- Choice of bottom or tangential discharge
- Option of explosion proof design

Benefits

- Flexibility - caters to differing products and particle size requirements
- Easy and efficient cleaning between batches
- Choice of discharge process overcomes limitations of plant size or layout
- Sanitary design available

Fine Grinding Mills

Kek® fine grinding Universal Mills are designed and constructed for high performance, robustness, easy maintenance and safety in use. These mills have been developed to meet the specific requirements of the food, pharmaceutical and chemical industries. A range of models is available to suit a variety of process and throughput requirements e.g., from a few lbs to several tons per hour.

Quality and Performance

Kek® Universal Mills ensure a controlled size reduction with a high degree of fineness achieved. Typical requirements are to grind materials of up to 3 Mohs hardness to within the ranges of 30 to 500µ mean particle size.

Mills are available in stainless steel or carbon steel with a variety of finishes such as bead blast or mirror polish.

Product Range

Model Size	Motor Size	Maximum Mill Speed rpm		Rotor Size mm	
	Grinding Rotor	Grinding Rotor Turbine/Screen	Grinding Rotor Pin & Disc	Turbine Screen	Pin & Disc
5H	3 kw	19000	19000	119	133
4H/WB	7.5 - 15 kw	10000	10000	227	250
3H/WB	15 - 30 kw	6000	8000	375	390
2H/WB	37 - 90 kw	4000	5000	570	550
1H/WB	100-150 kw	2850	2850	800	800

CIP/WIP

CIP (clean in place) and WIP (wash in place) are typical requirements for fine grinding applications particularly in the food, chemical, and pharmaceutical industries. Kek® Universal Mills can be custom designed to suit a specific application, layout or material.

Opposing Rotating Mill

Constructed with two sets of pinned disc grinding media facing each other within the mill. The two rotors are operated by separate motors and rotate in opposite directions. By setting the rotors at similar speeds, the actual grinding power is increased which enables the mill to grind tougher particles to finer specifications.

Grinding Media

Turbine and Screen

Developed for fine grinding of soft to medium hard materials, particularly those that are fibrous. The turbine develops high airflows which help to reduce grinding temperatures. This also makes the system ideal for harder crystalline, and heat sensitive products, such as sugar.

Pinned Disc

Designed for fine to very fine grinding of dry, brittle materials. The size and throughput of the ground product is controlled by varying the pin and disc configurations and the rotor speed.

Design specifications include:

- Seals up to 1.2 Bar hydrostatic loads for full flush capabilities.
- Retractable, flush mounting or tri-clover type mounting for nozzles or spray balls.
- Cleanable sintered filter elements.

Kek®
Universal
Mill



Customized design

Nitrogen Assisted Milling

Inerting

Use of inert gas to reduce oxygen level below combustion limit and thus prevents an explosion within the mill. This method offers protection against dust explosions and is advantageous when processing low / minimum emission energy materials. A further advantage is the low moisture content of the mill atmosphere which is a benefit when grinding hygroscopic materials.

Temperature Controlled

Temperature controlled milling involves the use of liquid Nitrogen as a cooling agent which is applied to the mill and collection system. This technology is often applied to either improve processing properties of heat sensitive materials or give a specified milled product output from the mill, where it is essential to eliminate temperature increase during normal milling, i.e. control of mill temperature from ambient mill temperature to -58°F .

Cryogenic Grinding

Cryogenic grinding systems also involve the addition of Nitrogen but the temperatures are much lower and cooling is applied to the mill system and the feed product. The object is to embrittle products that are impossible to mill at ambient temperatures. By cooling them to temperatures of -238°F , it is possible to grind these materials finely. Cool and Cryogenic grinding also provide the added benefit of inert explosion protection.

10 Bar Mill Systems

Applied to systems which are rated to 10 bar pressure shock containment, offering protection against potential dust explosion.

Inert System

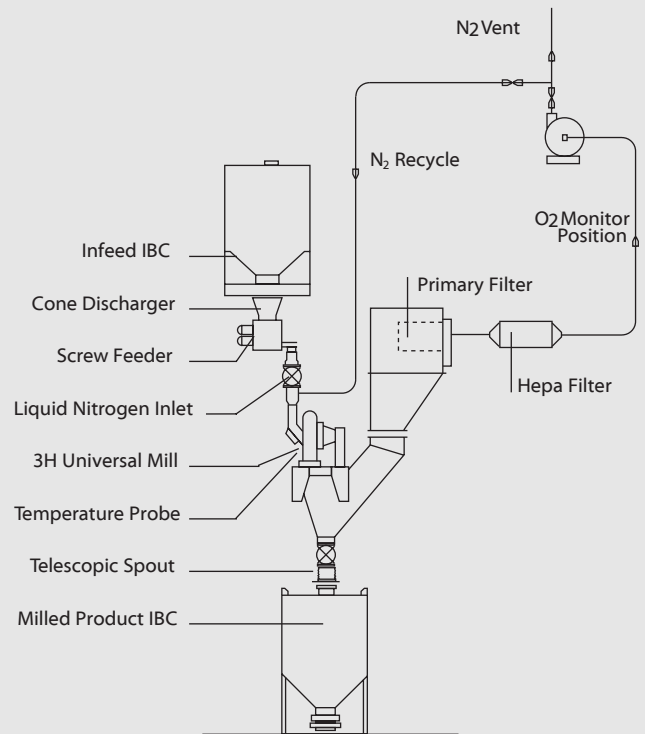

Temperature Controlled System

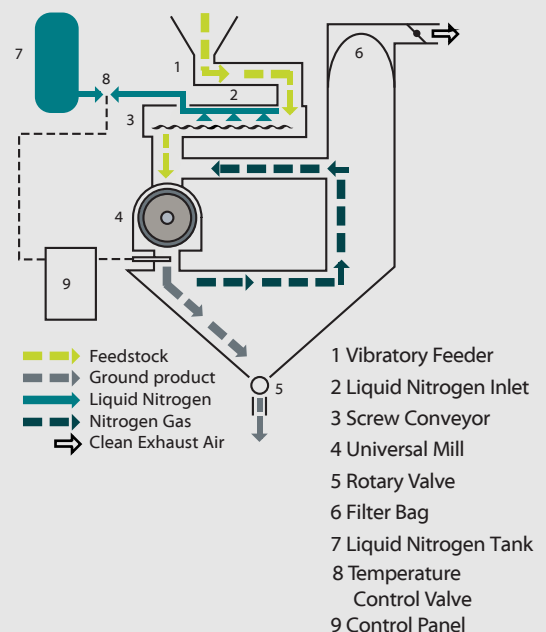

Closed Loop Milling Systems

Closed loop milling involves a process in which the mill airflow is totally recycled within the system back to the mill air intake. A requirement to provide filtration for the mill process air is unnecessary because there is no net airflow through the system. This makes the system more cost effective to design as a pressure shock resistant 'containment' system, and results in a compact installation.

Glove Boxes

Glove boxes are used in high containment applications and also offer CIP capabilities and other features such as remote drive through glove box with motor in non-isolated areas.

Closed Loop (filterless) and inerted Closed Loop systems are suited to use within Glove Boxes. The compact design enables use of a smaller enclosure with fewer penetrations through the walls. Optional extras include sound insulation, dust filtration and systems to vent, suppress or contain explosion risks and excess pressure of up to 10 Bar.

Closed Loop System

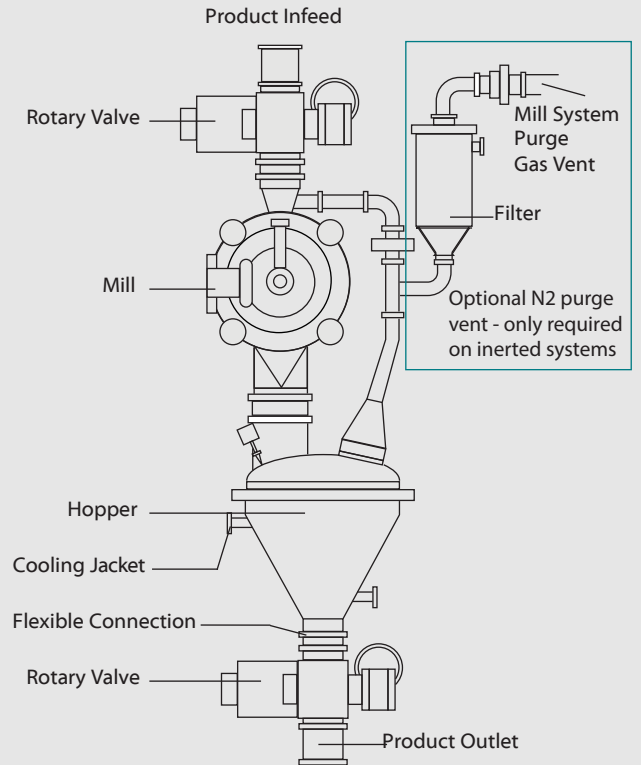

Remote Collection

With bottom discharge into "blowing boot" for vacuum transfer to remote collection hopper

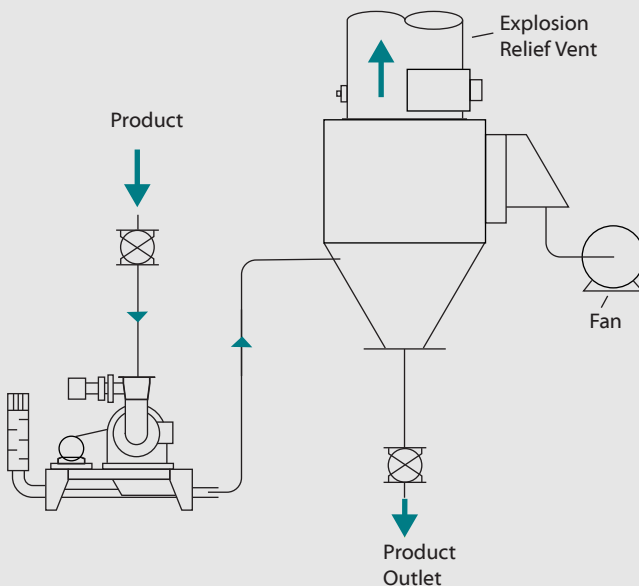

Gravity Fed

Gravity feed and discharge hopper with integral reverse jet filtration

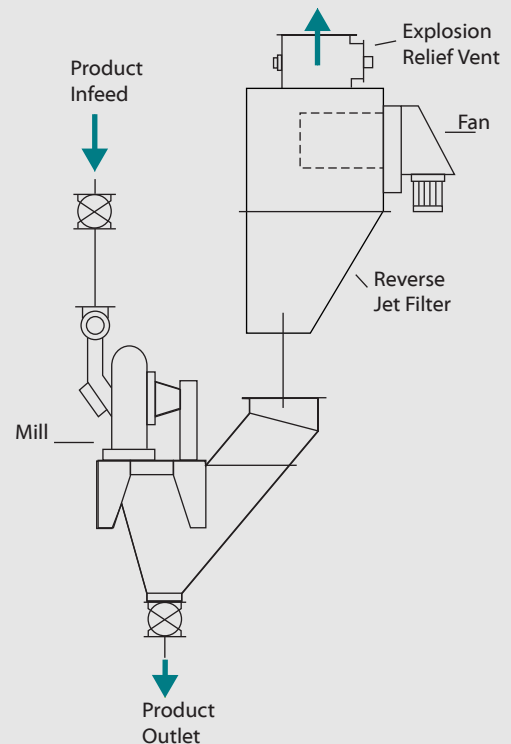

Applications

Food Industry Application

Kek® Universal Mills are designed with hygiene and easy cleaning in mind and are ideal for a wide variety of food applications, from hard crystalline products such as sugar or salt to soft, fibrous products such as wheat, barley, and oats.

Sugar Grinding

- Different grades of sugar can be achieved by varying the feed rate, the mill speed or the grinding medium.
- Minor ingredients such as tri-calcium phosphate or cornstarch to ground sugar can be easily added as the intense milling action ensures a homogeneous distribution.
- Sugar is a Group A explosion risk therefore appropriate explosion precautions must be taken.

Kemutec engineers have an in-depth understanding of explosion prevention, relief suppression and containment. Milling systems can be designed to meet not only your needs, but also those imposed by health and safety legislation.

Our PPS brand Air Classifier Mills are capable of achieving even finer grades of sugar. Please refer to our Technical Sales Department for more information.

Some uses of milled sugar	TYPICAL GRADE USED	
	US Specification	Particle Size Distribution
General Baking	6x	98% below 150µ
Biscuit/Cookie	10x	97.0% below 75µ
Confectionery & Ultrafine	12x	98% below 45µ

Spices

- Aromatic food products require special handling, as volatile oils are often degraded during conventional grinding at room temperature.
- Product is cooled to -238°F and below, using liquid nitrogen to preserve its integrity.

Cereals

- Kek® Universal Mills are ideal for grinding corn grits, oats, barley, wheat, rice and other cereals.
- Feedstock can be either whole grain or de-hulled, allowing production of bran or flour.
- The mill feed, speed and grinding media can be varied to obtain a limitless range of end-product specifications, from coarse brans to fine flours.

Dairy Products

- Maximum hygiene and thorough cleanability are of paramount importance in the dairy industry. These requirements are easily met by Kek® fine grinding mills.
- Milled products include whey powder, casein, lactose, and milk powder.



Typical fine chemical products:

- Carbonates
- Chlorates
- Chlorides
- Citric Acid
- Fertilizers
- Fungicides
- Gum Arabic
- Gypsum
- Hexamine
- Insecticides
- Metallic Salts
- Nitrates
- Oxides
- Pesticides
- Phosphates
- Stearates
- Talc
- Urea Resin

Typical pharmaceutical products:

- Analgesics
- Laxatives
- Anti-convulsants
- Gastric reflux suppressants
- Vitamins
- Cultures
- Aspirin
- Paracetamol



Fine Chemical Industry Applications

- Kek® fine grinding mills are also used to grind some of the most challenging and difficult products, while giving reliable and repeatable performance under arduous conditions.
- Kek® mills are ideal for colors, pigments and dyes where thorough cleaning between batches is necessary, because of their easy to clean, hygienic design.

Pharmaceutical Industry Applications

Fine grinding of pharmaceutical products requires high standards of hygiene and cleanability. Kek® fine grinding mills are designed to meet the most stringent requirements including prevention of cross contamination between batches which is vitally important in the pharmaceutical industry. Kemutec is happy to design a complete system to meet individual requirements and specifications.

- Choice of Materials of Construction and finish as required.
- Easily removable grinding media to ensure the mill can be thoroughly cleaned between batches.
- Double seal arrangement and air-purged seals prevent product ingress into the bearings and to prevent lubricant from contaminating the mill chamber.

BV-P5080EN All information is given without obligation.
All specifications are subject to change. © 2020



Kemutec - Part of Schenck Process Group
130 Wharton Road
Bristol, PA 19007
Tel: 215 -788-8013
Fax: 215 785-5113
Web: www.kemutecusa.com
Email: sales.kemutec@schenckprocess.com



we make processes work